

WCM-101

Rugged Mini PTZ Camera

❖ SAMSUNG Module
❖ 10X zoom camera
❖ 520TV Lines



SPECIFICATIONS

MECHANICAL

Pan	360° Endless Pan 0.1° to 100°/sec.
Preset Speed	110°/sec, ± 0.1° Accuracy
Tilt	-45° to 90° tilt angle (64steps proportional to zoom)
Preset Speed	60°/sec, ± 0.05° Accuracy
Weight	1.2kg
Dimensions	108.45(Ø) x 151.30(H) mm

ENVIRONMENTAL

Construction	Aluminum
Ingress Protection	IP64 (Outdoor Housing)
Color	Black or Cool Gray
Operating Temp	-20°C to 50°C (Fan&Heater power ON)
Humidity	0% to 90%

FUNCTIONS

Preset	63 points less than 0.1° accuracy
Tour	8 programmable
Pattern	4 patterns
Flip	Auto flip ON / Off (rotate 180° at bottom of tilt)
Auto Scan	4 (programmable speed and diagonal scan)
Privacy Zone	2 blocks with title (Masking / Video off)
Address	Up to 255 selectable ID (Rotary switch)
Control	RS-485 / RS-422 Multiple protocol
Alarm In	2 alarm (NO/NC, Priority)
Alarm Out	2 relay out (Hold, Latch)
Display	4 Area title Zone title on/off (start / end zone)

ELECTRICAL

Power	DC 12V, 600mA (Power adaptor not included)
Consumption	18.0 W (1.0A Max.)
Fan & Heater	42W

CERTIFICATION

CE EMC, FCC CLASS A, RoHS, E-mark

FEATURES

- 1/4" Super HAD CCD, Samsung optical 10x zoom
- Endless Pan rotation (-45 ° to 90 ° Tilt angle)
- Up to 63 programmable preset
- less than ±0.1° Preset Accuracy
- 8 programmable Tour, 4 Pattern
- Alarm - Move the camera to programmed Preset position with Alarm trigger.(Max. 2)
- 4 Scan(Programmable speed and diagonal scan)
- Programmable Privacy Masking(2 Zones)
- RS-422, RS-485 communication
- Multiple protocol (Pelco-D, Pelco-P, Wonwoo)
- Built-in Menu System for Setup of Programmable Functions
- Mechanical Auto Flip
- Programmable Zoom Speed(Optional Update tool)
- DC 12V, 600mA
- IP64
- E-mark for Vehicle Application

DIMENSIONS

Unit : mm

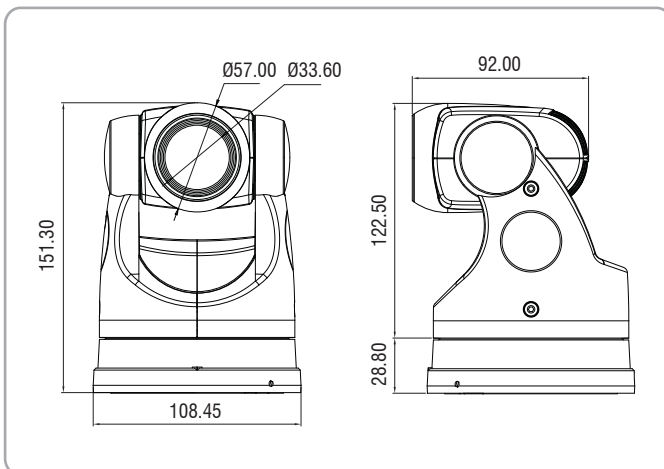

OPTIONAL HOUSING(WCMH-101)

Unit : mm

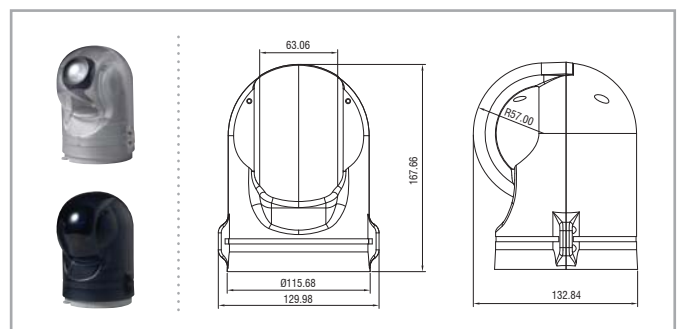

Rugged Mini PTZ Camera

CAMERA SELECTION

MODEL	WCM-101N	WCM-101P
Image sensor	1/4" Super HAD CCD	
Total Pixels	811(H) x 508(V)	795(H) x 596(V)
Effective Pixels	768(H) x 494(V)	752(H) x 582(V)
Scanning System	2 : 1 Interlace, 525 Lines / 60 Fields / 30 Frames	2 : 1 Interlace, 625 Lines / 50 Fields / 25 Frames
Synchronization	Internal	
Scanning Frequency	Horizontal : 15.734KHz	Horizontal : 15.625KHz
	Vertical : 59.94Hz	Vertical : 50Hz
Horizontal Resolution	Color(Wide) : 520TV Lines(Min.), B/W(Wide) : 570TV Lines(Min.)	
Video Output	CVBS : 1.0Vp-p / 75Ω	
Lens	Optical 10X, Digital 10x zoom f3.8 ~ 38.0mm (F2.8)	
Min. Focus Distance	1.0m	
Angle Field of View	Horizontal : Appr. 51.2°(Wide) to 5.58°(Tele)	
	Vertical : Appr. 39.3°(Wide) to 4.27°(Tele)	
Digital Zoom	Built-in (2X ~ 10X, Total 100X zoom)	
S / N Ratio (Y signal)	50dB (AGC off, Weight on)	
Min. Illumination	0.7Lux@F2.8 (50 IRE) : Color mode	
	0.02Lux@F2.8 (50 IRE) : B/W mode	
Back Light Compensation	Low / Middle / High / Off selectable	
Day & Night	Color / Auto1 / Auto2 / B/W (ICR filter change)	
Gain Control	Normal / High / Off selectable	
White Balance	ATW / AWC / Manual selectable (1800°K ~ 10,500°K)	
Electronic Shutter Speed	Auto / Manual selectable (1/60 ~ 1/120,000)	Auto / Manual selectable (1/50 ~ 1/120,000)
	DSS On / Off (Selectable limit ~ 128X)	
DNR	Low / Middle / High / Off selectable	
Function	63 Presets, 9 Tours, 4 Scan, 4 Area, 4 Pattern, 2 Alarm, Autoscan	

MODEL	WCM-101N	WCM-101P
Privacy Function	Max. 4 Programmable zones	
Preset Positions	63 Positions	
Rotation Angle	Pan : 360° Endless / Tilt : -45° ~ 190° (Mechanical auto flip)	
Rotation Speed	Pan : 110°/sec (Preset 110°/sec)	
	Tilt : 35°/sec (Preset 50°/sec)	
Flip	Auto flip ON / OFF	
Lens Initialization	Built-in	
Focus Control	Auto / Manual / One push selectable	
Iris Control	Auto / Manual selectable	
Protocols	PELCO-D, P, WONWOO	
Communication	RS-485	
Power Consumption	DC 12V (±10%), 1.5A	
Operating Temperature	-10°C ~ +45°C (No chilly wind)	
Operating Humidity	20% ~ 75% RH	
Certification	CE, FCC, RoHS, IP64, E-mark	
Dimensions	Ø108.45(W) x 151.30(H)mm	
Weight	1.2Kg	

BRACKET(WB-300)



INSTALLATION

